



Requesting American Forces Radio and Television Service (AFRTS)

The American Forces Radio and Television Service (AFRTS) operates the American Forces Network (AFN), a worldwide military radio and television broadcast network.

AFRTS equipment can be obtained two ways, by direct purchase or temporary loan. Both options require submission of a completed **"Request for Service"** form to AFRTS. The form is at the end of this document.

Programming on AFRTS is provided to the government at little or no cost by the program producers based upon the fact that we limit access to our programming to authorized audience members. This agreement is put into jeopardy by fraudulent use or distribution of AFRTS programming, which that could result in the termination of programming agreements. This could essentially take AFRTS off the air. Do your part and safeguard this vital morale enhancer. Report lost or stolen decoders and suspected fraudulent use or distribution of the AFRTS signal directly to AFRTS at afrtops1@hq.afis.osd.mil.

Access to AFRTS programming is restricted by DoD regulations. You are eligible to receive AFRTS programming if you meet the following criteria.

- Active Duty US military stationed or deployed overseas and their accompanying family members.
- DoD civilians assigned or deployed overseas and their accompanying family members.
- Direct Hire US Government State Department employees assigned overseas.
- DoD Direct Hire Contractors who are US citizens and directly sponsored by the host command.
- Retired US military members with a current DoD ID card.

DoD Contractors must meet additional eligibility requirements

- Command supported DoD contractors overseas must have an official identification card issued by the DoD, Combatant Command or Major Command.
- This ID must be presented at any military exchange in order to purchase a decoder.
- If purchasing a decoder through the mail, the supported command must fax or scan and email a copy of the ID to DSN 312-328-0624 (fax) or decoders@hq.afis.osd.mil
- Military commands may purchase decoders for use by authorized contractors, but the decoders must be registered to the command, not individual contractors.

1. Obtaining Loaned AFRTS equipment

Loaned AFRTS equipment must be set up in an area where the majority of the troops assigned will have access to the programming. Systems set up in morale tents, mess tents or similar areas meet this requirement. **AFRTS satellite signal decoders, satellite dishes, low noise block converter (LNB's), line amplifiers and other equipment, excluding cable, that is released to a unit on a temporary loan must be returned to AFRTS upon completion of the deployment.** The unit that receives AFRTS equipment is fiscally responsible for the gear until it is returned to AFRTS.

AFRTS signal decoders are individually addressable and controllable, just like the commercial satellite providers Direct TV or Dish Network in the United States. This means that AFRTS can "turn off" decoders that are missing, stolen or still activated after the date the receiving unit listed as their rotation date from the deployed location. It is critical each unit maintain frequent contact with the Air Force Broadcasting Service and update changes in location, rotation date or personnel responsible for AFRTS equipment in order to prevent decoder deactivation.

2. Direct purchase of AFRTS equipment

Units that deploy often are highly encouraged to use unit funds to purchase the equipment needed to obtain the AFRTS signal. Purchasing the equipment will allow your unit near instant access to AFRTS programming at any deployed location practically anywhere on the planet outside the United States. Since you control the equipment, you won't have to wait for it to be shipped to you or run the risk of it getting lost in the supply system.

All requests for purchase must be routed through the Air Force Broadcasting Service and AFRTS in order to obtain purchase authorization.

Units can procure the Scientific Atlanta Model D9835 AFRTS integrated receiver/decoder (IRD) through the Television-Audio Support Activity site <http://tasa.dodmedia.osd.mil/log/index.htm>. A help file is available on the "requisition on-line processing" page. Here is the detailed info...

<p>FSC: 5820 NIIN: 01P800076 Noun: RECEIVER, SATELLITE Estimated Unit Cost: \$236.00 Unit of Issue: EA Source of Supply: BS7 Cage Code: 42061 Manufacturer: SCIENTIFIC ATLANTA Part Number: 4016130 Model Number: D9835</p>	<p>Description: RECEIVER, SATELLITE; 4:2:0 NTSC CH3/4 MODULATOR; ONE STEREO PAIR/TWO MONO CHANNELS; CAPABLE OF RECEIVING DIGITALLY ENCRYPTED VIDEO, AUDIO AND VBI DATA; PROVIDES VARIABLE RATE TO TRANSITION EXISTING ANALOG SERVICE TO DIGITAL; FREQ RANGE: 950-2150MHZ; 75 OHM IMPEDANCE; INCLUDES: FIELD UPGRADEABLE SOFTWARE AND SECURITY, ON-SCREEN MENU FOR SETUP AND STATUS, 64 USER-EDITABLE PRESET CONFIGURATIONS, REMOTE CONTROL AND POWER CORD (CUSTOMER MUST SPECIFY COUNTRY OF USE.....); ROHS-6 COMPLIANT; PWR RQMTS: 100-240VAC, 50/60HZ.G).</p>
---	---

Several distributors offer dishes that will work with our satellite network. One example of an AFRTS-compatible off-the-shelf 1.5 meter dish, LNBF and cable bundle comes from Patriot Antenna Systems. Many other sources are available, and can be found via Internet search. The following is an example of the accessories needed for the set up of the Patriot bundle:

PTX-150AZJ-GOV

- 1) 1.5 Ku-band meter offset antenna with AZ/EL mount (Ku band for use with the AFRTS Hotbird 4 satellite service)
- 1) Dual tray non-penetrating mount assembly
- 1) Wide band LNBF
- 1) 100 foot length of RG-6 with F-connectors attached

Cost of system is \$297.00, plus shipping, for orders of 10-25 systems. Less than this amount, add another 25% to the amount for shipping and handling charges. More information is available from Norm Bruner, Patriot Antenna Systems, (402) 545-2222, e-mail nbruner@sepatriot.com or www.sepatriot.com.

3. Levels of Service

Levels of service are tailored in scope from small to large. TVRO and L-Band distribution are the most common options in use today.

A. Television Receive-Only (TVRO): This system consists of a single satellite dish and one decoder, feeding one to three televisions. This system is used in common-use areas (dayrooms, dining facilities, or other large-gathering areas) where one channel per group is sufficient. The channel viewed is determined by the channel selection on the signal decoder, and not the TV. If more than one TV is set up to one decoder, the same program channel will be seen on all TV's connected to the decoder.

B. L-Band Distribution: This system consists of one satellite dish feeding multiple decoders (normally 10 or less). Each decoder feeds one television. L-Band systems are generally installed in small or mid-size buildings or compounds, and allow individual decoder users to select a specific AFN programming channel to view.

C. Cable Television Head-End (CATV): CATV systems consist of a pre-wired rack of equipment designed to supply individual AFRTS video-level signals to multiple points, usually at fixed, larger locations. These multiple points, or drops, allow a customer to connect a television to the cable system and receive AFRTS programming without the need for a dedicated decoder. CATV is usually installed at bases or in large buildings, and may feed as many as 300 drops. Due to the complexity of this system, a site survey must be conducted by AFRTS personnel at the requesting unit's expense. A CATV system head-end system also must be purchased by the requesting unit.

D. Microwave Multi-Point Distribution System (MMDS): This is basically wireless cable. The programming signal is acquired from the satellite and broadcast over the MMDS system. To receive programming, each building or tent would need a down converter. The converter receives the signal that is then fed into the structure via co-axial cable. The MMDS system is ideal for temporary or highly flexible base camps, in that cable trenching is not required and adding or eliminating service to areas is as simple as installing or removing the down converter. When compared to fully trenched cable distribution, the cost for MMDS is considerably less expensive. Obtaining frequency approval from the Combatant Command frequency manager is required and is the sole responsibility of the requesting organization.

E. Over-the Air (OTA) Radio and/or Television: OTA TV consists of a TVRO system connected to a low-power television or radio transmitter. Separate transmitters and antennas are needed for each broadcast channel, but with this configuration, customers can receive individual AFN television channels without the need of a separate decoder and cabling. OTA TV is normally used in relatively stable situations and is normally installed in geographically remote areas; i.e. away from metro areas. In addition to providing television programs, AFRTS also offers OTA FM radio broadcast equipment. OTA radio consists of a TVRO system connected to one or more FM transmitters capable of up to 1,000 watts. OTA radio is relatively common in stable contingency situations where they offer the most effective means of providing command information and news to deployed personnel. **Note: The requesting organization must obtain Host Nation approval (in writing) and an authorized frequency from the Combatant Command frequency manager. Additionally, a copy of the authorization letter must be filed with the Air Force Broadcasting Service and AFRTS before any radiated signal is placed in operation.** The requesting unit may be required to purchase the required transmitter equipment.

F. Manned AFRTS service is usually only approved for established main operating locations. Close coordination with the Combatant Command, American Forces Radio and Television Service and the Air Force Broadcasting Service is required. The requesting organization is required to fund the first two years of broadcast operations.

4. Equipment

Satellite Dish: All programming is provided via Satellite downlink. Where you are in the "footprint" of a satellite signal determines the size of satellite dish required to obtain a quality signal. If you're going to purchase a satellite dish on the local economy, ensure the Low Noise Block (LNB) is a Universal KU-Band, 10.7-11.8 GHz. Ensure you check for the lower frequency (10.7 GHz) as some European designed KU-Band LNB's only go down to 10.8 GHz. American Forces Network decoders operate on 10.755 GHz input and a 10.8 GHz LNB will cause the signal to be degraded.

We highly recommend that all satellite dishes be secured with sandbags and that a sandbag wall be constructed around the dish in order to protect the dish from high winds. Unsecured dishes or those that do not have some protection from strong wind could result in the loss of the satellite dish or signal distortion. The following satellite dish azimuth and elevation information can be used to align your dish to the Hotbird 4 satellite.

Satellite Signal Decoder: The AFRTS signal is encrypted and only signal decoders provided by or purchased from AFRTS or a military exchange are capable of acquiring the signal. All decoders can pick up and distribute AFN radio and TV programming

Line Amplifiers: If you have long cable runs in excess of 200', you'll need to add in a line amplifier. The line amp will boost the signal strength allowing clear reception.

5. Programming

The programming you receive is determined by your geographic location. Your unit must be in the "footprint" of one of the many satellites that AFRTS uses to distribute programming worldwide. More information about programming is available at <http://myafn.net> by clicking on "Decoder Set Up" under "AFNINFO."

6. Satellites used to distribute AFRTS Programming

AFRTS SATNET (Satellite Network)

NewSkies NSS-5 (C-band)

Location: 183 degrees East
 Band: C
 Transponder Antenna polarization: Left-hand circular
 Receiver Setting Polarization: "H-fixed" for model 9234 consumer-grade decoders or "H" for commercial-grade decoders with dual-band LNBS
 C Band Downlink Frequency: 3.97713 GHz
 Transponder: 44
 L-Band: 1172.75 MHz
 Symbol Rate: 28.0000 MS/s
 FEC Rate: $\frac{3}{4}$
 EIRP: 41.0 dBW
 Network ID: 2
 Coverage Map:
<http://www.newskies.com/nss5coverage.htm>

NewSkies NSS-6 (Ku-band)

Location: 95 degrees East
 Band: Ku
 Transponder Antenna polarization: Horizontal
 Receiver Setting Polarization: "H-fixed" for model 9234 consumer-grade decoders or "H" for commercial-grade decoders with dual-band LNBS
 Ku Band Downlink Frequency: 12.6470 GHz
 Transponder:
 Symbol Rate: 28.0000 MS/s
 FEC Rate: $\frac{3}{4}$
 EIRP: 53.7 dBW center pattern
 Network ID: 1
 Coverage Map:
<http://www.newskies.com/nss6coverage.htm>.

INTELSAT 10-02

(South America, Africa, and Atlantic Ocean Region)

Location: 359 degrees East (1 degree West)
 Band: C
 Transponder Antenna Polarization: RHCP
 Receiver Setting Polarization: "H-fixed"
 C-Band Frequency: 4.1750 GHz
 Transponder: 38
 L-Band frequency: 975 MHz
 Symbol rate: 28.0000 MS/s
 FEC rate: $\frac{3}{4}$
 EIRP: 35 dBW
 Network ID 3
 Coverage Map:
<http://www.intelsat.com/images/en/resources/coverage/maps/maps/10-02-359-global.jpg>

IntelSat Galaxy 28 (United States)

Location: 89 degrees West
 Band: C/L Band
 C-band frequency: 4.060 GHz
 Transponder: 118
 Transponder Antenna Polarization: HP
 Receiver Setting Polarization: "H-fixed" for model 9234 consumer-grade decoders or "H" for commercial-grade decoders with dual-band LNBS
 L-Band frequency: 1090 MHz
 Symbol rate: 28.0000 MS/s
 FEC rate: $\frac{3}{4}$
 EIRP: 41.9 dBW
 Network ID 9
 Coverage Map (not official):
http://ww2.intelsat.com/special/IA8_e/IA8_maps.asp#

HotBird 6 (Europe)

Location: 13 degrees East
 Band: Ku
 Transponder Antenna Polarization: Vertical
 Transponder: 129
 Receiver Setting Polarization: "H-fixed" for model 9234 consumer-grade decoders or "H" for commercial-grade decoders with dual-band LNBS based on transponder settings
 Ku Band Downlink Frequency: 11.096 GHz
 L-Band/LO frequency: 1025 MHz* (9.750 MHz LNB Frequency)
 Symbol rate: 28.0000 MS/s
 FEC rate: $\frac{3}{4}$
 EIRP: 50.0 dBW
 Network ID 6
 Coverage map:
<http://www.eutelsat.org/satellites/coverage/download/13ehb4.gif>

HotBird 7A (Europe)

Location: 13 degrees East
 Band: Ku
 Transponder Antenna Polarization: Vertical
 Transponder: 113
 Receiver Setting Polarization: "H-fixed" for model 9234 consumer-grade decoders or "H" for commercial-grade decoders with dual-band LNBS based on transponder settings
 Ku Band Downlink Frequency: 10.775 GHz
 L-Band/LO frequency: 1025 MHz* (9.750 MHz LNB Frequency)
 Symbol rate: 28.0000 MS/s
 FEC rate: $\frac{3}{4}$
 EIRP: 50.0 dBW
 Network ID 6
 Coverage map:
<http://www.eutelsat.org/satellites/coverage/download/13ehb4.gif>

Direct To Sailor (DTS) Service

INTELSAT 701 (Pacific Ocean Region)

Location: 180 degrees East
 Band: C
 Transponder Antenna Polarization: LHCP
 Receiver Setting Polarization: "H-fixed"
 C-Band frequency: 4.1735 GHz
 L-Band frequency: 976.5 MHz
 Symbol Rate: 3.6800 MS/s
 FEC rate: 2/3
 EIRP: 29.0 dBW
 Network ID 5
 Coverage map:
<http://www.intelsat.com/images/en/resources/coveragemaps/maps/701-180-global.jpg> (global)

INTELSAT 906 (Indian Ocean Region and Persian Gulf)

Location: 64.1 degrees East
 Band: C
 Transponder Antenna Polarization: LHCP
 Receiver Setting Polarization: "H-fixed"
 C-Band frequency: 4093.5 MHz
 L-Band frequency: 1056 MHz
 Symbol Rate: 3.6800 MS/s
 FEC Rate: 2/3
 EIRP: 29.0 dBW
 Network ID 7
 Coverage map:
<http://www.intelsat.com/images/en/resources/coveragemaps/maps/906-64-global.jpg> (global)

New Skies NSS-7 (Atlantic Ocean Region and Mediterranean Sea)

Location: 338.0 degrees East (22 degrees West)
 Band: C
 Transponder Antenna Polarization: LHCP
 Receiver Setting Polarization: "H-fixed"
 C-Band frequency: 4115 MHz
 L-Band frequency: 1035 MHz
 Symbol Rate: 3.6800 MS/s
 FEC Rate: 2/3
 EIRP: 30.5 dBW
 Network ID 6
 Coverage map:
<http://www.newskies.com/nss7coverage.htm>

AMC-1 C Band Domestic Hop (Very large domestic dishes only)

Location: 103 degrees West
 Band: C
 Transponder Polarity: Horizontal
 Receiver Setting Polarization: "H-fixed"
 C-Band frequency: 4.065.75 GHz
 L-Band frequency: 1.084.25 GHz
 Network ID 9
 Coverage map: <http://www.ses-amicom.com/satellites/amc-1.htm>

AMC-1 Ku Band (The Pentagon Channel)

Location: 103 degrees West
 Band: Ku
 Transponder Polarity: Vertical
 Receiver Setting Polarization: Vertical
 Ku band frequency: 12.100 GHz* Transponder number: 20
 Symbol Rate: 20,000 MS/s
 FEC Rate: 3/4
 Encryption: none
 Coverage map: <http://www.ses-amicom.com/satellites/amc-1.html>

*Important note on LNB frequencies:

All C-band LNB's have a local oscillator (L.O.) frequency of 5.150 GHz but Ku-band LNB's may come in many different frequencies - typically 9.750 to 12.75 GHz. This means that if you're attempting to watch a Ku-band service you need to set the decoder's frequency using a bit of simple math. The formula to set the Ku-Low/Single L.O. frequency on the AFRTS decoder is the downlink frequency minus the L.O. frequency. As an example the downlink frequency for the INTELSAT 804 satellite serving the Japan and Korea Direct to Home service area is 11.6380 GHz. An LNB with a local oscillator frequency of 10.000 GHz would give a Ku Low/Single L.O. frequency of 1638 MHz (1.638 GHz) by working the math problem $11.6380 - 10.000 = 1.638$. One of the Ku-band satellites serving the European region is HotBird 7A at 13 degrees east and has a downlink frequency of 10.775 GHz. Connecting an LNB with a local oscillator frequency of 9.750 would result in a receiver frequency of 1025 MHz ($10.775 - 9.750 = 1.025$ GHz which is 1025 MHz).

7. Useful links

Policy and procedural information on AFRTS activities can be found in Department of Defense 5120.20-R, **“Management and Operation of Armed Forces Radio and Television Service”** Nov 98. This regulation can be downloaded at http://www.dtic.mil/whs/directives/corres/pdf/512020r_110998/p512020r.pdf

Set up and troubleshooting information for AFRTS satellite systems can be found in the **“AFRTS Satellite Handbook”** that is available at http://www.afrts.osd.mil/tech_info/page.asp?pg=handbook

To activate your AFRTS decoder, go to the **“Authorize Decoder”** link at www.pvconnect.net

Your unit Department of Defense Activity Address Code (**DoDAAC**) can be checked at <https://dodaac.wpafb.af.mil/>

Check out programming schedules tailored to your specific time zone by visiting the **AFRTS Programming Guide** available at <http://www.myafn.net>

MIPR or Form 9 procedures for purchasing AFRTS equipment for permanent unit retention can be found at the Television – Audio Support Activity (T-ASA) web site <http://tasa.dodmedia.osd.mil/>

8. Points of Contact

<p>CENTCOM Contingency Support Element (CSE) OL-A, AFNEWS, Ramstein AB, Germany Unit 3375 Contingency Support Element APO AE 09094-3375 DSN (V) 314-480-5767, Comm 49-6371-475767 DSN (F) 314-480-9934, Comm 49-6371-479934 Email: exo.ola.rfs@ramstein.af.mil</p>	<p>PACOM Contingency Support Element (CSE) OL-C, AFNEWS, Yokota AB, Japan Unit 5091 Contingency Support Element APO AP 96328-5091 DSN (V) 315-225-7153, Comm 81-3117-55-7153 DSN (F) 315-225-2362, Comm 81-3117-55-2362 Email: olc.exo.rfs@yokota.af.mil</p>
<p>IRAQI FREEDOM AFN Support Center NCOIC, Tech Planner, AFN-Iraq MFO Camp Victory/Slayer, Baghdad, Iraq Email: AFN-IRAQ-MFO@iraq.centcom.mil DSN: 318-835-1541/2136 Secure VOIP: 241-9210 Iraqna: 0790-111-0574</p>	<p>ENDURING FREEDOM AFN Support Center CFC-Afghanistan Bagram AB, Afghanistan DSN (V) 318-431-4358</p>
<p>Additional points of contact for programs, policy and procedural issues</p>	
<p>(Worldwide/All Commands) American Forces Radio & Television Service (AFRTS) Email: afrtops1@hq.afis.osd.mil DSN(V) 328-616, Comm 703.428.0616 DSN(F) 328.0616, Comm 703.428.0616</p>	

9. Request for Service form and physical layout requirements

Due to the high value of AFRTS equipment and fiscal responsibility incurred by accepting the gear, the unit commanders name, email and DSN number must be included on the request form in the Unit Commander block.

The requester identifies the individual that has been designated as the unit POC for all AFRTS matters. Whenever possible, a single person should be appointed by a commander to coordinate all AFRTS activity for all units associated with a Wing or Brigade level organization. This person will work all AFRTS issues for the Wing/Brigade and subordinate units.

All equipment is shipped through military supply channels. If available, equipment can be sent via FEDEX, DHL or another express carrier at the expense of the requesting unit. If this option is desired, the requesting unit will forward the billing information to the AFRTS entity shipping the equipment.

The Department of Defense Activity Address Code (DoDAAC) is a six character alpha-numeric combination that specifically identifies a unit. **All units have a DoDAAC and you should contact your unit supply element to obtain the deployed DoDAAC for your unit.** All equipment sent via military supply is sent to the DoDAAC and we must have this information in order to process your request.

Using MS Word drawing or MS Power Point, block out the physical lay out of your location. Indicate where you plan on setting up service and the approximate distance, in feet, between all locations as shown in the example below. Include your physical layout file along with your completed request for service form.

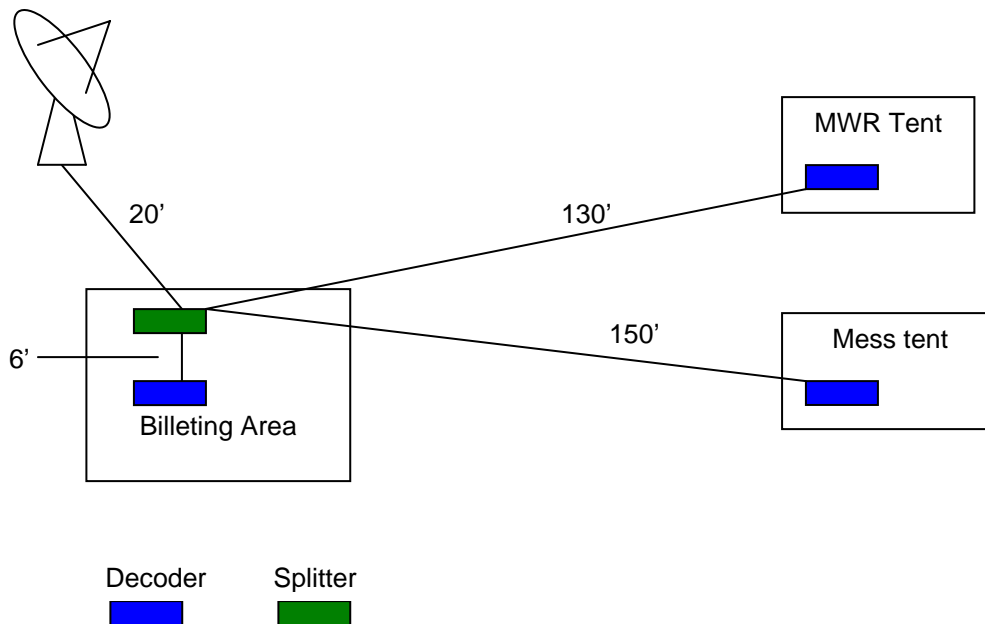

American Forces Radio and Television Service Request Form					
All fields MUST be completed			Date Submitted:		AFRTS Tracking Control Number
Requester:					
Unit Commander:					
Home Station Information	Parent Unit				
	Unit Address				
	Phone	DSN		Comm	
	Fax				
	Email				
Deployed Station Information	Deployed Unit				
	Unit Address				
	Phone	DSN		Comm	
	DoDAAC		verify your deployed DoDAAC at https://dodaac.wpafb.af.mil/		
	Email				
	Country/City				
Audience breakdown by number and service	Army		Deployment Length		
	Air Force		Rotation Date		
	Navy		List locations where systems will be set up		
	Marines		<input type="checkbox"/> Messing tent/area	<input type="checkbox"/> Passenger Terminal	
	Coast Guard		<input type="checkbox"/> Morale tent/area	<input type="checkbox"/> Command Post	
	DoD Civilians		<input type="checkbox"/> Fitness tent/area	<input type="checkbox"/> Other:	
		<input type="checkbox"/> Billeting	<input type="checkbox"/> Other:		
Determine level of service requested	<input type="checkbox"/> Limited AFN TV receive only satellite dish/decoder system for 1 to 3 TV's.				
	<input type="checkbox"/> Limited area cable distribution system for multiple buildings up to 10 cable drops				
	<input type="checkbox"/> Large base-level cable distribution system with a cable head end				
	<input type="checkbox"/> Microwave Multi-Point Distribution System (MMDS) (frequency approval required)				
	<input type="checkbox"/> Over the Air (OTA) broadcast of AFN Radio (frequency approval required)				
	<input type="checkbox"/> Over the Air broadcast of AFN Television (frequency approval required)				
	<input type="checkbox"/> Manned radio and/or television station (Combatant Command coordination required)				
Determine requirements	Number of AFRTS signal decoders needed				
	Number of Satellite dishes needed				
Determine cable lengths required	Distance between the projected location of the satellite dish and decoder				
	Distance between each decoder and TV				
	Number of TV's to be connected to a decoder				
Requesting Units: Send completed Request for Service form to afrtops1@hq.afis.osd.mil					